



Betriebsanleitung

Bremssattel- und Radnabenmontagehilfe

4972-1/3

4972-1

4972-3

4972-4

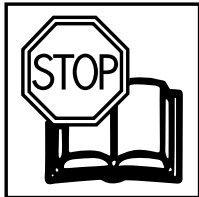
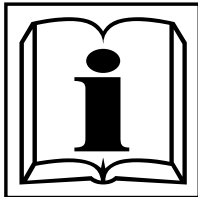

Schwingende Last



HAZET Youtube-Channel



max. 75 kg

Hebehilfe
4972-3



Haltewerkzeug Radnabe
4972-4,
max. 70 kg



Bremssattel-Halter
4972-1,
max. 35 kg

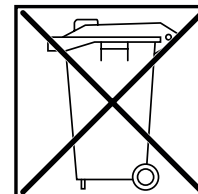
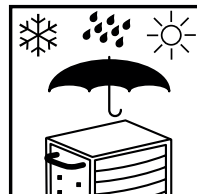
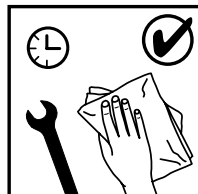



Hebehilfe, 4972-3

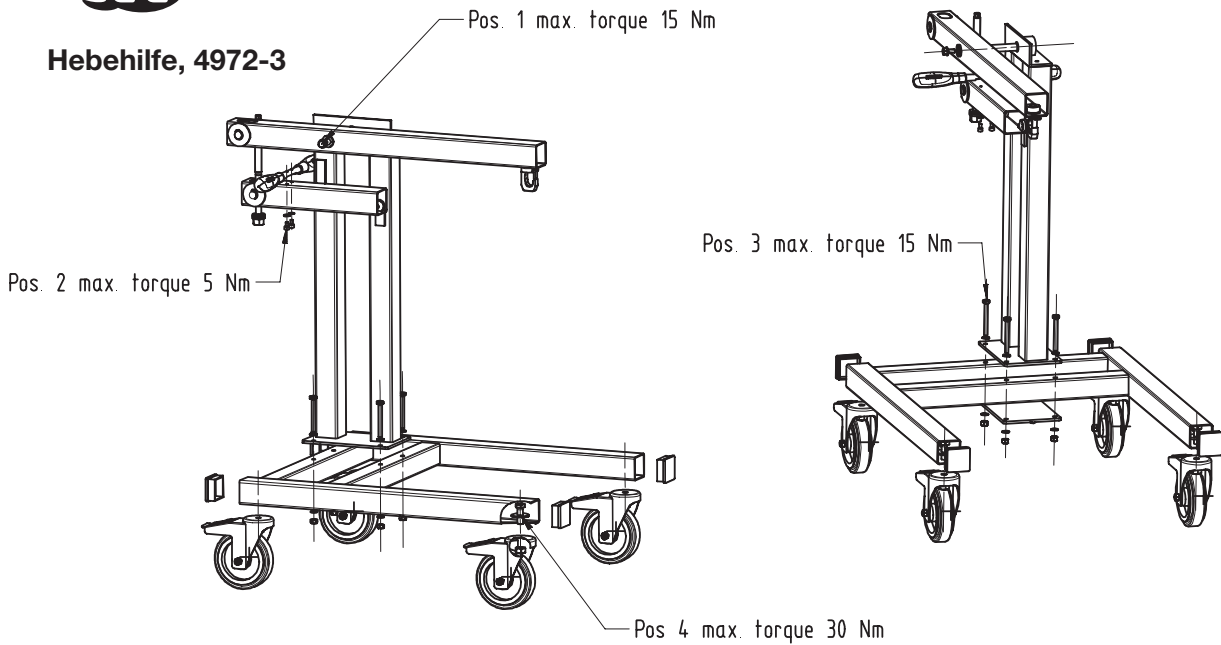

Bremssattel-Halter, 4972-1

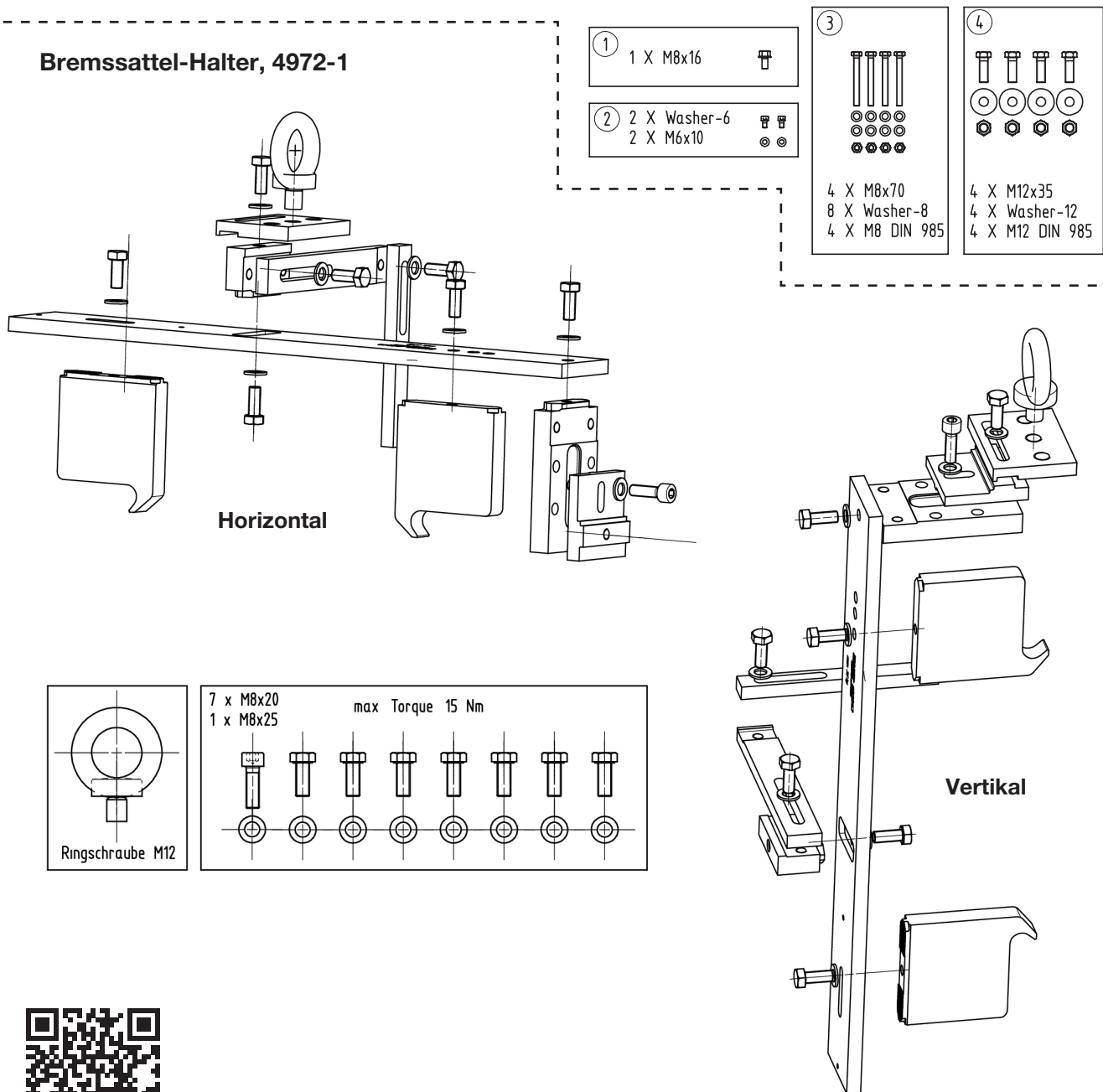

Bestimmungsgemäße Verwendung:

Die Bremssattel- und Radnabenmontagehilfe, ist ausschließlich zum Demontieren und Montieren von Bremssätteln- und Radnaben im Nutzfahrzeugbereich bestimmt. Alle darüber hinausgehenden Verwendungen, gelten als nicht bestimmungsgemäß.

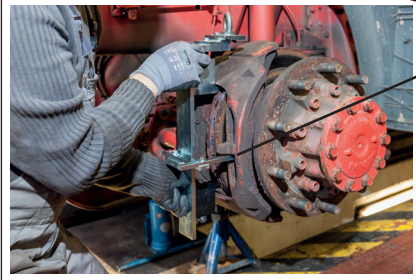
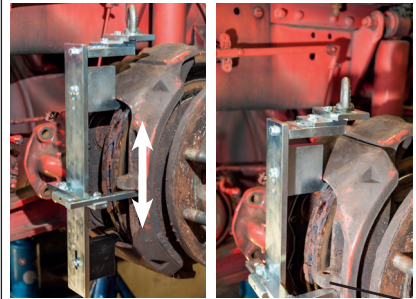
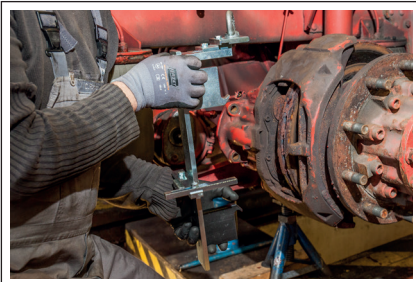

- Führen Sie den Bremssattel-Halter 4972-1 an den Bremssattel heran.

- Durch die Verstellbarkeit des schwarzen Hakens, kann dieser individuell verstellt werden.

- Die seitliche Halterung muss so eingestellt werden, dass diese spielfrei am Bremssattel anliegt, um ein Verdrehen und Kippen des Bremssattels zu verhindern



- Passen Sie die Haken entsprechend an und verklemmen diesen sicher im Bremssattel.

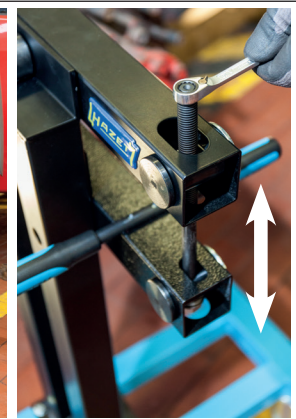
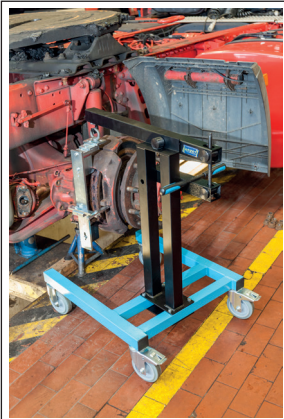

- Führen Sie die Hebehilfe 4972-3 an den Bremssattel-Halter 4972-1 heran, sodass Sie den Haken der Hebehilfe 4972-3 in die Ringschraube einhängen können. Die Höhe kann über die Spindel eingestellt werden SW10.



- Ist der Bremssattel-Halter 4972-1 sicher in dem Haken der Hebehilfe 4972-3 aufgenommen, und der Bremssattel sicher und fest im Bremssattel-Halter 4972-1 befestigt, können die Befestigungsschrauben des Bremssattels gelöst werden.

ACHTUNG! Achten Sie unbedingt auf festen und korrekten Sitz des Bremssattel-Halters 4972-1, damit der Bremssattel richtig und sicher gehalten wird.



- Ist der Bremssattel sicher gehalten führen Sie die Hebehilfe mit dem Bremssattel aus dem Achsbereich.

ACHTUNG! Bei der Bremssattelmontage ungleich 12 Uhr, muss sich der schwarze bewegliche Haken unten befinden, um ein durch die Gewichtskraft verursachtes Bewegen des Bremssattels zu vermeiden.

4972-2 Schwenklager:

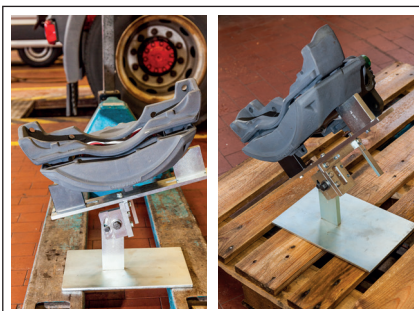

HINWEIS! 4972-2 Schwenklager zu Demontage und Montage von Bremssätteln an LKW, Omnibus, Trailer, und Anhängerachsen, welche in diagonaler „Uhrzeigerstellung zwischen 20:00 und 17:00 Uhr“ verbaut sind.

- Schwenklager 4972-2 mit Bremssattel-Halter 4972-1 verbinden und z.B. mit Hubwagen unter dem Bremssattel platzieren. Dadurch wird nun ein einfaches Anfädeln der Schrauben auch in ungünstigen Positionen ermöglicht – wenn nötig kann die Winkel-lage über das Schwenklager angepasst werden. Hierzu lösen Sie die 8er Schraube und passen die Winkellage an.
- Bitte achten Sie unbedingt auf die vorherigen Montagehinweise des Bremssattel-Halters 4972-1 und den sicheren Halt des Bremssattels!

Halte-Werkzeug Radnabe 4972-4:



- Positionierung ausschließlich, wie in der Abbildung!
- Bei falscher Montage (180° gedreht), verändert sich die Schwerpunktlage derart, dass die komplette Radnabe nach dem Lösen eine Schwenkbewegung vollzieht und Menschen zu Schäden kommen können!

ACHTUNG! Um ein Herausrutschen der eingehängten Last zu verhindern, muss nach jedem Einhängen der Werkzeuge, das Blockierblech am Aufnahmehaken in die ursprüngliche, vertikale 6 Uhr Lage gebracht werden!
Nur so kann ein Herausgleiten der Lasten in ungünstigen kinetischen Fällen verhindert werden!

Bitte beachten Sie, dass Sie die Feststellrollen beim Abstellen der Hebehilfe blockieren, um eine eigenständige Fortbewegung zu verhindern.

Operating Instructions



Assembly aid for brake callipers and wheel hubs

4972-1/3

4972-1

4972-3

4972-4

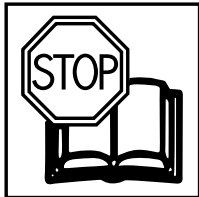
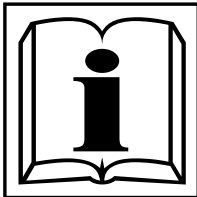

Swinging load



HAZET Youtube-Channel



max. 75 kg

Lifting aid
4972-3



Holding tool wheel hub
4972-4,
max. 70 kg

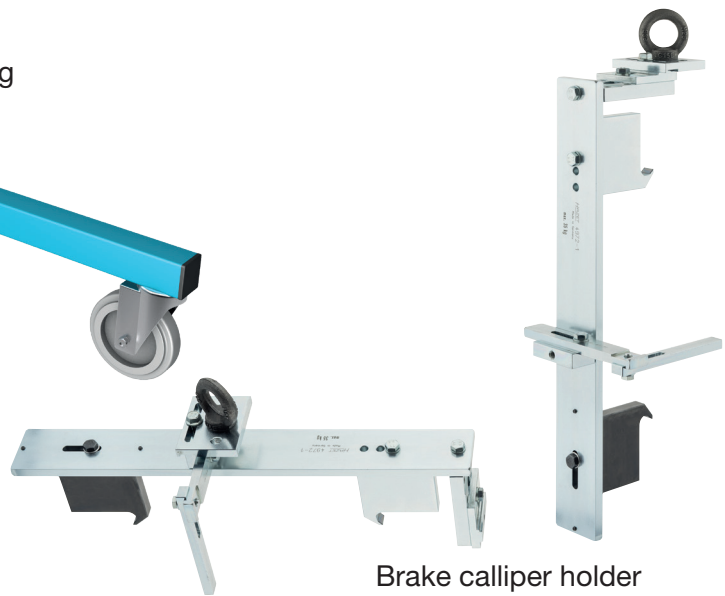

Brake calliper holder
4972-1
max. 35 kg



www.hazet.de/en/products/general-workshop-equipment/



www.hazet.de/en/service-centre

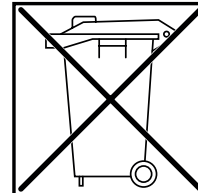
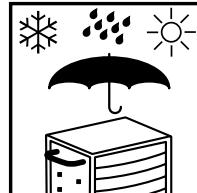
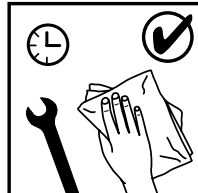

Lifting aid, 4972-3

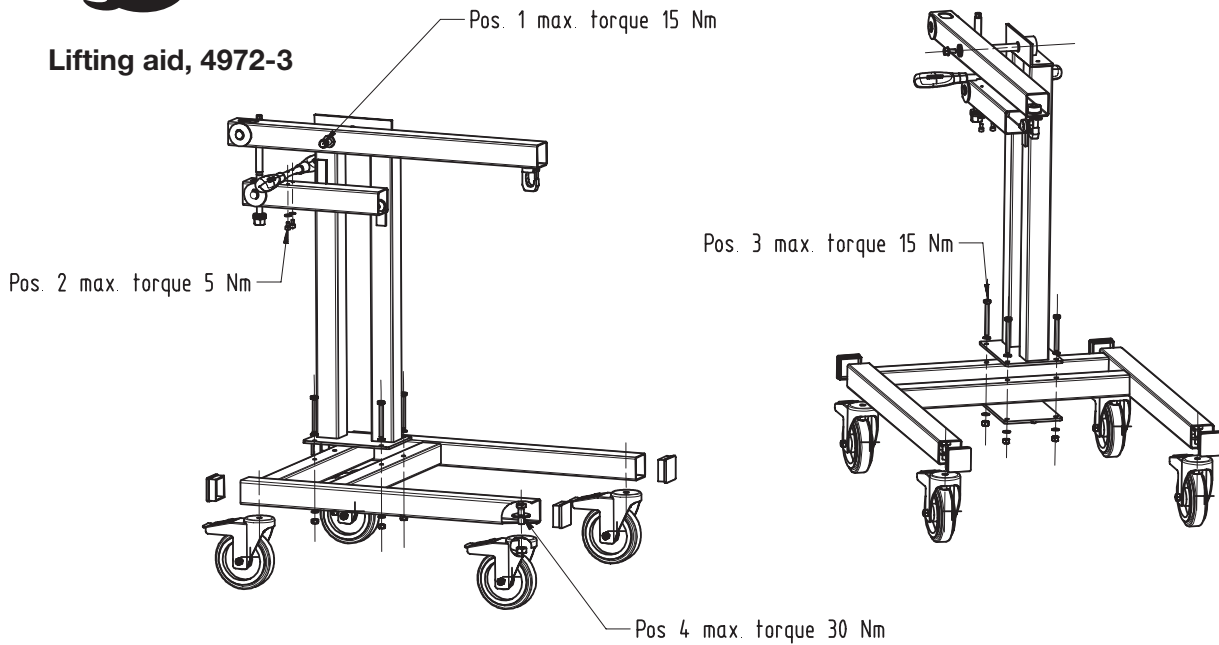

Brake calliper holder, 4972-1

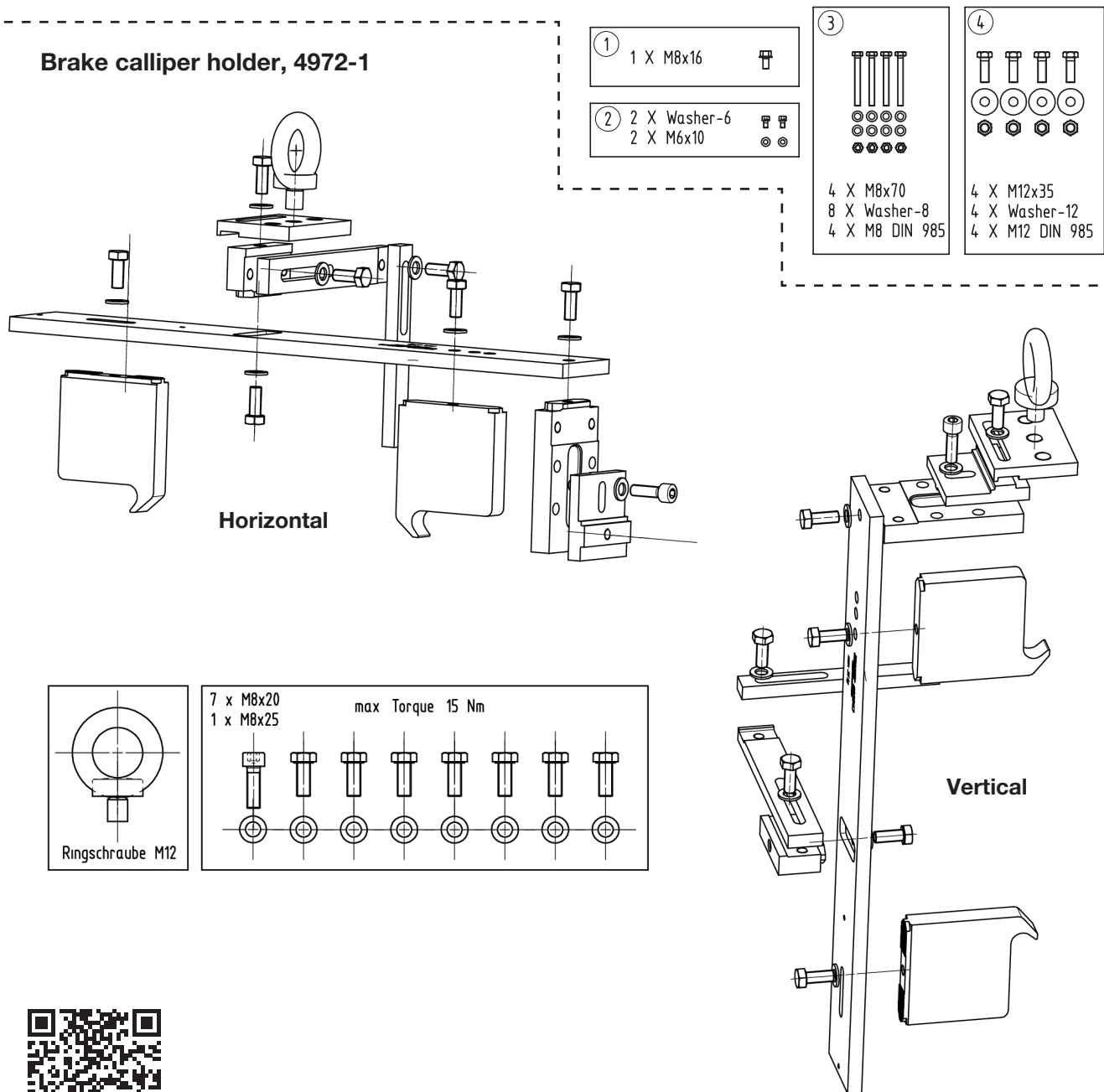

Intended use:

The brake calliper and wheel hub lifting aid is intended exclusively for the assembly and dis-assembly of brake callipers and wheel hubs in the commercial vehicle sector. All other uses are deemed to be improper.

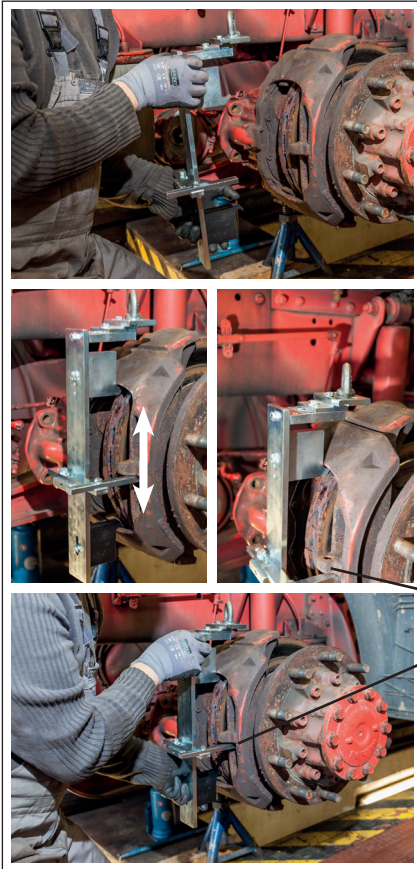

- Bring the brake calliper holder 4972-1 over to the brake calliper.

- The adjustability of the black hook allows it to be individually adjusted.
- The lateral bracket must be set so that it sits against the brake calliper without clearance, in order to avoid the brake calliper distorting or tipping over.



- Adjust the hook as necessary and clamp it securely into the brake calliper.



- Bring the lifting aid 4972-3 to the brake calliper holder 4972-1, so that you can hook the lifting aid 4972-3 into the eye bolt. The height can be set using the spindle SW10.



- Once the brake calliper holder 4972-1 is securely attached to the hook of the lifting aid 4972-3, and the brake calliper is securely and firmly mounted in the brake calliper holder 4972-1, the fastening screws of the brake calliper can be unscrewed.

CAUTION! Make absolutely sure that the brake calliper 4972-1 is situated firmly and correctly so that the brake calliper is held securely and properly.



- Once the brake calliper is securely held, move the lifting aid with the brake calliper out of the axle area.

CAUTION! For brake calliper assembly not at 12 o'clock position, the black movable hook must be positioned below, in order to avoid gravity causing the brake calliper to move.

4972-2 Swivel bearing:



NOTE! 4972-2 Swivel bearing for disassembly and assembly of brake calliper in trucks, buses, trailers and trailer axles that are installed in a diagonal "clockwise position between 8 o'clock and 5 o'clock".

- Connect swivel bearing 4972-2 to brake calliper holder 4972-1 and place under the brake calliper with e.g. lift truck. This enables easy threading of the screws even in awkward positions – if necessary, the angle position can be adjusted using the swivel bearing. To do this, loosen the size 8 screw and adjust the angle position.

- Please observe the previous assembly instructions for the brake calliper holder 4972-1 and make sure the brake calliper is securely held!

Holding tool wheel hub 4972-4:



- Position only as shown in the illustration!
- In the case of incorrect assembly (rotated 180°), the centre of gravity changes such that the entire wheel hub will swivel after loosening and people may be injured!

CAUTION! To prevent the hanging load from slipping out, the blocking plate at the receiving hook must subsequently be restored to the original, vertical 6 o'clock position each time a tool is hooked in!

This is the only way to avoid the loads sliding out in poor kinetic conditions!

Please ensure that you lock the casters when parking the lifting aid, in order to prevent it from moving forward independently.